



**Instruction manual**

**UNIVERSAL-PROGRAMMABLE  
CONTROLLER**

**TECON 202**

Programm 202 - 001.9

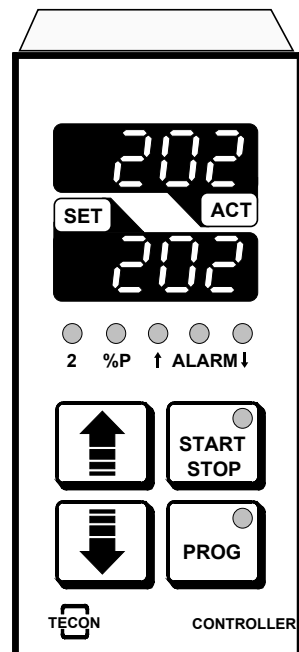

# UNIVERSAL CONTROLLER TECON 202

## Contents :

1. Safety regulations .....	4
1.1. Purpose of application of the unit.....	4
1.2. Range of application .....	4
1.3. Control range .....	4
1.4. Maximum and minimum temperature.....	4
1.5. Operating safety of the control system.....	4
1.6. Instruction, Manipulations on the unit.....	4
2. Technical data, functions .....	4
2.1. Overview .....	5
2.2. Method of function .....	7
3. Installation.....	8
3.1. Connections .....	8
3.2. View of back wall.....	8
3.3. Dimension sketch.....	9
3.4. Connection of the sensors .....	9
3.5. Mounting .....	10
3.6. Dismounting.....	10
4. Operation of the controller.....	11
4.1. Indication and operating elements .....	11
4.2. Setting the nominal value.....	11
4.3. Starting and stopping of the controller.....	11
4.4. Alarm.....	11
4.5. Starting the program .....	12
4.6. Stopping the program.....	12
4.7. Procedure in case of a power down .....	12
4.8. Function check.....	12
4.9. Control quality .....	12
4.10. Indication of software version, alarms and system errors .....	13
5. Programming the controller.....	14
5.1. Temperature program .....	14
5.2. Program sector .....	14
5.3. Program run .....	14
5.4. Program setting.....	14
6. Adapting the controller .....	16
6.1. Possibilities .....	16
6.2. Adaptation within the protected range.....	16
6.3. Alarm data.....	18
6.4. Serial interface .....	22
6.5. Sensors.....	22
6.6. Controller parameters .....	25
6.7. System configuration.....	27
6.8. Analogue inputs and outputs.....	30
6.9. Offsets.....	33

7. Program example .....	34
7.1. Needed temperature profile .....	34
7.2. Program input .....	34
8. Serial interface .....	37
8.1. General .....	37
8.2. Operation with higher ranking control unit:.....	37
9. Error messages, faults .....	39
9.1. Error messages of the controller .....	39
9.2. Faults during operation .....	39
9.3. Repairs and guarantee .....	40
10. Designation code .....	41
11. List of program data .....	42
12. List of adjustment data.....	43

## 1. Safety regulations

### 1.1. Purpose of application of the unit

The TECON 202 is designed to control heating and/or cooling systems. The unit is fitted with a temperature sensor for the control function and if required, a second sensor can be fitted for monitoring. According to execution of type, the unit can be fitted with relay contacts or voltage (= signal), or current outputs. Before using the unit, the type indication should be consulted to see which components are fitted for the relevant application.

### 1.2. Range of application

This unit must *not* be used in explosion hazarded areas. The unit must not be exposed to rain , nor must it be used in any moist environment

The unit is designed for use at temperatures between 0 and 50°C and a relative humidity of air of between 10 and 90%. The mains voltage has to correspond with the type description and may not deviate from this value more than 10%. It is imperative that the protective earth is (PE) is connected.

Depending on the connected temperature sensor, the unit can control temperatures up to 1800°C. The user carries all responsibility for any hazards forthcoming from the generation of high temperatures.

### 1.3. Control range

The control range has to be adapted. (s. Sensors, on page 15 ff. ). The nominal value can be adjusted within this range.

### 1.4. Maximum and minimum temperature

The maximum temperature, above which no more heating is effected, and the minimum temperature, below which no more cooling is effected, have to be adjusted (s. Adaptation of alarm data, page 18 ff.).

### 1.5. Operating safety of the control system

When correctly adjusted and providing the system is operating correctly, the control range (pt. 1.3) and maximum and minimum temperature (pt. 1.4) avoid false operations .

In case damage can be caused in the event that the controller does not operate correctly, it is recommendable to install a safety cut-out

**TECON will gladly advise you**

### 1.6. Instruction, Manipulations on the unit

It is the responsibility of the user that he understands the operating instructions and that no manipulations are made on the unit which could affect its safe functioning. In particular, the unit must not be opened.

## 2. Technical data, functions

## UNIVERSAL CONTROLLER TECON 202

### 2.1. Overview

<b>Temperature sensors</b>	Thermocouples:	Measuring range:
	NiCr-Ni (K)	-200 to 1200 °C
	Fe-Co (J)	-200 to 750°C
	Pt10Rh-Pt (S)	0 to 1600°C
	Pt13Rh-Pt (R)	200 to 1600°C
	PtRh18 (B)	200 to 1800°C
	Nicrosil-nisil (N)	-200 to 1200°C
	Resistor:	
	Pt 100	-200 to 750°C
	Pt 100 with Zener barrier 84 Ohm	-200 to 400°C
<b>Temperature measurement</b>	Standard signal :	
	4- 20 mA	-200 to 2000°C
	0- 20 mA	-200 to 2000°C
<b>Actual-value</b>	Accuracy :	0.3% of the range
	Resolution :	32000 points
	Number of measurements per second	10
<b>Nominal value</b>	Indication :	4 digits, LED 14mm height
	Resolution:	programmable 0.1 °C or 1 °C
	Range :	according to selected sensor
<b>Limit value</b>	Indication :	4 digits, LED 14mm height
	Resolution :	programmable 0.1 °C or 1 °C
	Range :	can be adjusted and limited
	Entry :	with 2 keys or through external analog signal or via serial interface
<b>Control system</b>	Following values can be programmed and indicated and alternatively be sent to an output:	
	- Maximum temperature	
	- Minimum temperature	
	- Deviation from nominal value upward	
	- Deviation from nominal value downward	
	- Program - end	
	- Power down	
	The control unit contains 2 PID-controllers which can be programmed for heating or cooling.	
	Range of the control parameters :	
	Proportional band	0 to 999 °C
	Lead time	0 to 999 s
	Lag time	0 to 9999 s
	Relay interval time	1 to 999 s
	Dead range between heating/cooling	0.1 to 99.9 °C

## UNIVERSAL CONTROLLER TECON 202

<b>Outputs</b>	2 controller outputs alternatively: - Relay contact (normally open contact) 230V , 2A - signal output for thyristors etc. 24V , 20mA - continuous current output 4-20mA or 0-20mA 1 Limit-value output: - relay contact (change-over contact) 230V , 2A
<b>Analogue outputs</b>	Sensor temperature, nominal value, control deviation or control signal (capacity) programmable on 2 outputs 1mV/°C range -0.2 to 2.0 V 10mV/°C range -2.0 to 10.0 V Voltage programmable 0 to 10 V Current programmable 4-20mA or 0-20mA Resolution of the DA-converter 8000 points
<b>Digital input</b>	for external controlling of the control unit 24V, 7mA programmable
<b>Digital output</b>	for external linkage of the controller 24V , 20mA programmable
<b>Serial interface</b>	for linking of controllers to master-slave systems or for connection to other control systems (RS 485) : - baud rate 9600 - parity odd - data bits 7 - stop bits 1 - handshake none
<b>Temp. programs</b>	16 program sectors, consisting of 1 ramp, 1 dwell temperature and 1 dwell time, selectable by key. Ramp 0 to 999.9°C/h Dwell temperature acc. to setpoint range Dwell time 0 to 9h59min or infinite
<b>Special executions</b>	On demand, TECON programs the controller according to specifications as required by the customer
<b>Mains supply</b>	alternately 230/115V , 50/60Hz, 10VA
<b>Ambient temperature</b>	0 to 50°C
<b>Ambient humidity</b>	10 to 90% r.h.
<b>Dimensions</b>	Front frame 48 x 96 mm , 5mm high Controller with case can be exchanged from the front, can be mounted in any position mounting depth 125 mm
<b>Weight</b>	approx. 0.6 kg
<b>Type of protektion</b>	Panel IP 64 Enclosure IP 20
<b>Safety</b>	EN 60065
<b>EMC</b>	Immunity pr EN 50 082-2 Emission EN 50 081-1

## 2.2. Method of function

The TECON 202 controller contains 2 PID controllers which, according to requirements, can form one controller for heating and one for cooling, 2 controllers for heating, or 2 controllers for cooling. However, if the controller is used for 2 control systems both systems work with the same nominal value and both are started and stopped together (2-zone control).

The controller can switch heaters on and off directly via thyristors or relays and can control the heating capacity by changing the pulse-spacing ratio. But also a servo motor can be controlled via the two outputs. Continuous final control elements, such as control valves or phase control systems, can be actuated via the current outputs or one of the two analogue outputs.

If the controller has to function within a higher ranking system it can be linked in various manners. The nominal value can be applied as analogue signal. Nominal value and actual value, the difference between nominal value and actual value and the correcting variable (capacity) are available in form of analogue values. A digital input can be used for external controlling and a digital output signals the condition of the controller. The values of the nominal and actual temperature, the correcting variable, the controller condition, the alarm data and the control parameters can be polled and entered via the serial interface.

The range of control can be programmed. A relay contact is available as output for various monitoring systems. It can be set for a fixed temperature threshold, for a certain deviation of the temperature from the nominal value, or signalling the end of the program. Whether the function is to be used as an alarm or merely as a message to control other devices, can be selected, since the alarm indications can be suppressed.

16 temperature program sectors each can be feeded in and are called and started by keystroke.

Example: Program with four sectors

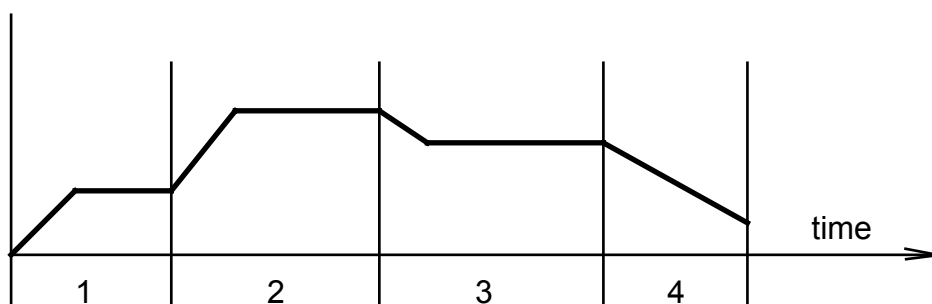

### 3. Installation

#### 3.1. Connections

On the back wall of the unit there are 2 rows of plug-in type screw terminals with 15 connections each. The section of the connecting wires is max. 1.5 mm.

**It is essential that the protective earth (PE) is connected.**

#### 3.2. View of back wall

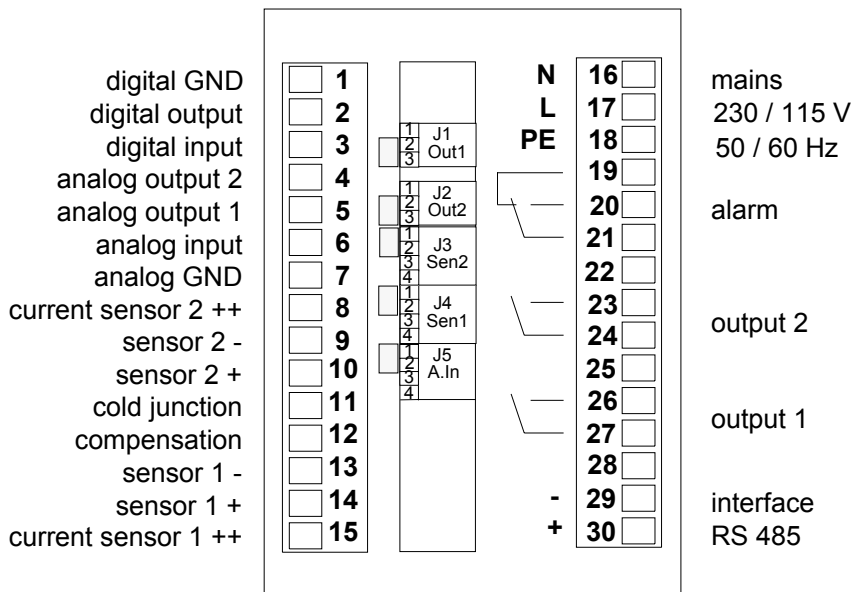

##### 3.2.1. Controller outputs

Ordering info:	202-XXXX.X-XXX.X	output 1	output 2
	↓		
	0	26 <input type="checkbox"/> Relay 27 <input type="checkbox"/>	23 <input type="checkbox"/> Relay 24 <input type="checkbox"/>
	1	26 <input type="checkbox"/> Signal 24V 27 <input type="checkbox"/>	23 <input type="checkbox"/> Relay 24 <input type="checkbox"/>
	2	26 <input type="checkbox"/> Relay 27 <input type="checkbox"/>	23 <input type="checkbox"/> Signal 24V 24 <input type="checkbox"/>
	3	26 <input type="checkbox"/> Signal 24V 27 <input type="checkbox"/>	23 <input type="checkbox"/> Signal 24V 24 <input type="checkbox"/>
	4	26 <input type="checkbox"/> 0/4-20mA 27 <input type="checkbox"/>	23 <input type="checkbox"/> Relay 24 <input type="checkbox"/>
	5	26 <input type="checkbox"/> Relay 27 <input type="checkbox"/>	23 <input type="checkbox"/> 0/4-20mA 24 <input type="checkbox"/>
	6	26 <input type="checkbox"/> 0/4-20mA 27 <input type="checkbox"/>	23 <input type="checkbox"/> 0/4-20mA 24 <input type="checkbox"/>
	7	26 <input type="checkbox"/> Signal 24V 27 <input type="checkbox"/>	23 <input type="checkbox"/> 0/4-20mA 24 <input type="checkbox"/>
	8	26 <input type="checkbox"/> 0/4-20mA 27 <input type="checkbox"/>	23 <input type="checkbox"/> Signal 24V 24 <input type="checkbox"/>

# UNIVERSAL CONTROLLER TECON 202

## 3.3. Dimension sketch



## 3.4. Connection of the sensors

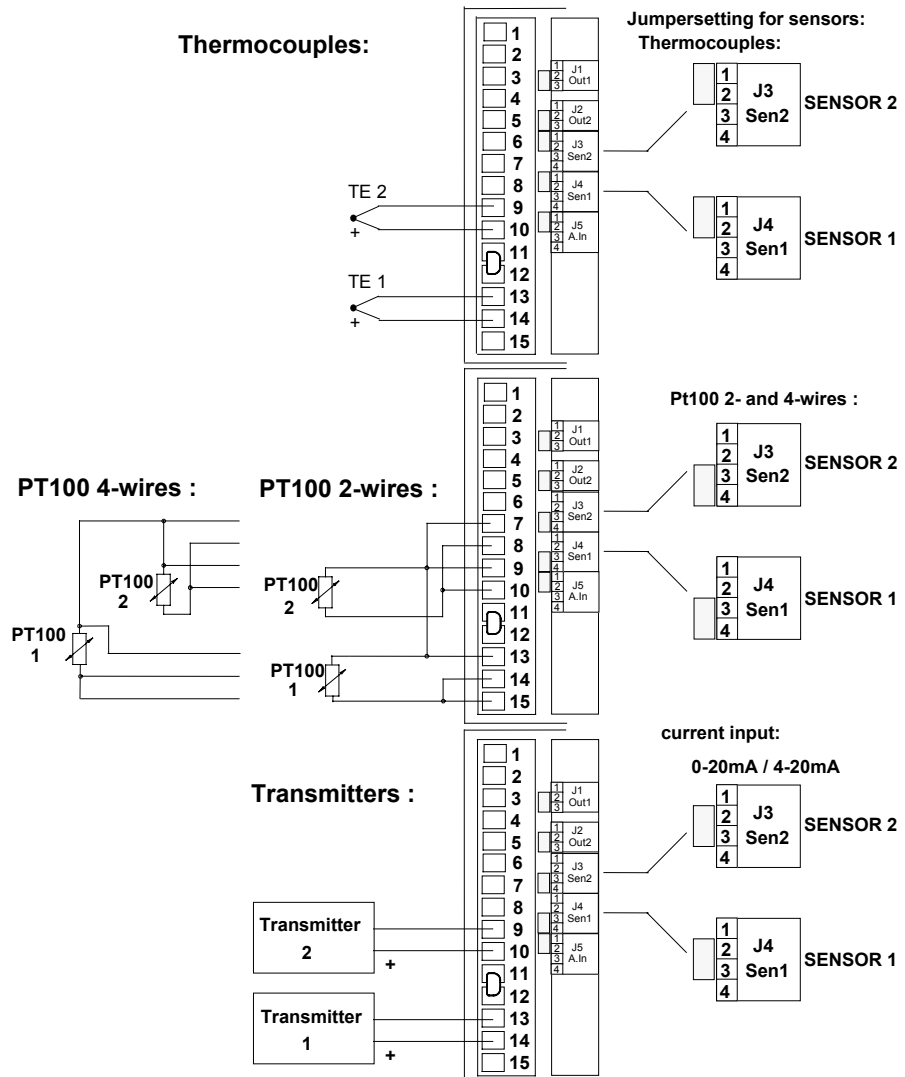

### 3.5. Mounting

Cut-out of control panel: : 44 x 92 mm  
Thickness of control panel 1 - 4 mm

Insert the two terminal strips through the cut-out of the panel and plug them in. (The mains input side is coded and can only be plugged in on that side)  
The controller is slid into the cut-out of the panel from the front and is fixed to the front panel by means of 2 screws.

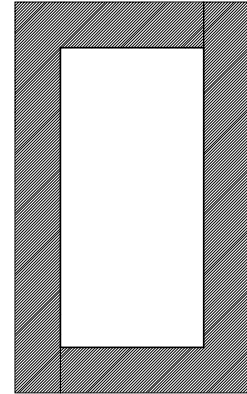

### 3.6. Dismounting

Undo the two screws in the front panel so that the controller can be pulled out from the front. Disconnect the two connector strips.

## 4. Operation of the controller

### 4.1. Indication and operating elements

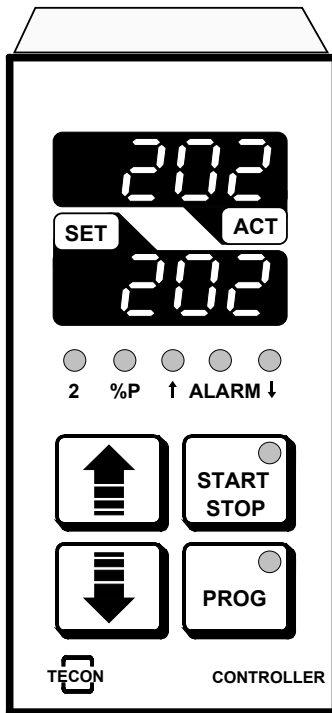

2 4 digit display

upper display : actual value  
lower display : nominal value  
(according to selected indication )

7 LED for function control

LED 2	= Data controller 2
LED %P	= Capacity
LED ↑	= Output controller 1
LED ALARM	= Alarm
LED ↓	= Output controller 2
LED Start/Stop	= Controller on/off
LED Prog	= cont.: Program running interim: Programming-mode

4 keys for operation

### 4.2. Setting the nominal value with the keys



### 4.3. Starting and stopping of the controller

Start with key

The LED in the key indicates that the control unit is on  
Stop with key

When the control system is switched off the LED is not lit.



### 4.4. Alarm

When an alarm is triggered the red LED indicated with Alarm lights up. At the same time the alarm indication flashes on the upper display providing the indication has been programmed with the relevant alarm code (see page 20). The alarm is acknowledged with the key



**4.5. Starting the program**

By pressing the key "PROG" one of the set programs is started ( in the upper indication "Strt" is displayed) now select with the arrow key the wanted number of program (displayed in the lower indication). To acknowledge press the key "START/STOP" .

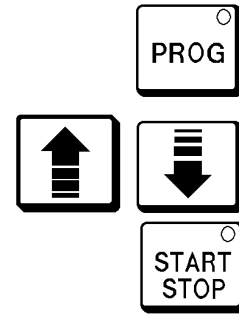

**4.6. Stopping the program**

The program can be stopped at any time by pressing the "START/STOP" key . To interrupt the running program and later continue use the digital input (see system data page 28).



**4.7. Procedure in case of a power down**

After the power has been restored the controller continues running at the same condition as before the power down event. An alarm is triggered if such has been configured (alarm code 3). If the alarm code 3 is set higher than 3, the controller always turns off after a power down.

**4.8. Function check**

When the control system is running the LED '###' shows that the first controller is switched on. The LED '###' shows the condition of the 2nd controller. The current output can be polled with key If 2 individual controllers have been programmed their values can also be polled with key If a program is running, its conditions are indicated by repeated pressing of the key ( Displayed is sector number and ramp or remaining time.)



**4.9. Control quality**

In case the controlling quality is not up to standard it is advisable to adapt the parameters. To that end see section 6, page 26 ff. However, the controller can perform this adaptation also of its own accord if following conditions have been fulfilled:

- ### No ramp must be run during start-up.
  - ### The difference between starting temperature and the set nominal value must be 5% or more of the adjusted control range and higher than 10°C.
  - ### The nominal value must not be altered during the adaptation process.
  - ### The controller is not operating with external nominal value.
  - ### Adaptation is only possible for the heating parameters, and only when controller 1 has been configured as heating controller.
- When these conditions are fulfilled the controller performs the adaptation when the 'START/STOP' key is pressed for at least 3 seconds. The adaptation is indicated by the flashing of the LED in the 'START/STOP' key.

#### 4.10. Indication of software version, alarms and system errors

On power on, the software version is shown for a few seconds



If an alarm comes up, for which the indication is programmed, it is shown blinking in the upper display.

(Alarm programming see page 18).



On power on, the device executes several self-tests. An error is shown in the following way:

The code of the error numbers is given in 'Error messages, faults' on page 39.



## **5. Programming the controller**

### **5.1. Temperature program**

A temperature program is operating with one or more program sectors. There are 16 possible program sectors.

### **5.2. Program sector**

A program sector includes one dwell temperature, one temperature ramp programmed in °C per hour, one dwell time programmed in hours and minutes, and the number of the following sector.

If the ramp is set to zero, the dwell temperature is immediately approached. If the dwell time is set to --.-- it lasts forever. This means, this sector has to be stopped manually. The shortest possible dwell time is 0.

The number of the following sector determines, where the program continues after ending. Thus every sector between 1 and 16 can be set as next sector. If the own or a number already being programmed is set, the program will run in a loop until manual stop. With the following sector number = 0, the program ends with this sector.

### **5.3. Program run**

At start the ramp begins at momentary temperature. The nominal value of the ramp runs with the indicated gradient until dwell temperature. The program sequence code defines if dwell time starts immediately at the beginning of the sector or when the nominal ramp value is equal to the dwell temperature or when the actual value has reached a certain limit around dwell temperature (see page 27).

### **5.4. Program setting**



























If during the program setting more than one minute no key is pushed, the controller will return to normal operation. By pushing the program key during 3 seconds the program setting can be stopped at once.

The mode for program setting is shown by the green LED in the "PROG" key flashing. The values are set by the arrow key.

By short pressing of the "PROG" key, it switches to the next setting value. If this key is pressed between 1 and 2 seconds, returning to the preceding value is possible.

Program sectors can not be deleted, they just can be overwritten. For setting, control, and changes proceed as follows:

## UNIVERSAL CONTROLLER TECON 202

Step	Press key	Indication	Function
1	 during 3sec		By entering the code defined by the user (new unit = 0) programming will be enabled. Without valid code the data can only be checked. This step is only necessary when data has to be altered.
2			The code is acknowledged and if correct, can now be readjusted. If the code was wrong these two steps are skipped.
3	 		
4			Starting the programming. The number of the sector is displayed and can be set by the arrow keys.
5	 		
6			The nominal value of the program sector is set in °C. The range can be programmed at system data setting and sensor choice (see par. 6, page 15 )
7	 		
8			The dwell time is set in hours and minutes. Range: 0 to 99 h 59 min. --.-- means infinite dwell time. It is selected by setting the dwell time < 0.
9	 		
10			The ramp is set in °C per hour. Range: 0 to 999.9°C/h. If zero is set the controller switches directly to the set nominal value .
11	 		
12			The following sector is selected. If needed all 16 program sectors can be programmed by repeating step 6-11. Following sector = 0 terminates the program. Ending programming by pressing 3 sec. the "PROG" key.
13	 		

The programs are stored during 10 years in the controller. Nevertheless it is highly recommended to record these data. For this purpose see the tables on page 43.

## 6. Adapting the controller

### 6.1. Possibilities

The temperature controller can be adapted to the specific case of application within wide limits. The adaptation takes place within code protected areas for:

- alarm data
- serial interface
- sensors
- control parameters
- system data
- analogue inputs and outputs
- offsets

#### 6.1.1. Alarm data

The conditions under which the alarm relay should switch and when an alarm indication has to take place can be programmed with alarm codes for the two sensor inputs and a code for the general alarm routine. Since the alarm indication and acknowledgement can be switched off, the two different alarm values can also be used for temperature related switching.

#### 6.1.2. Serial interface

The transmitting data, the device address and an alarm time for stopping the control in the event of failure of the connection, can be adjusted for linking with other controllers or with higher ranking systems.

#### 6.1.3. Sensors

The type of sensor used and the nominal-value range can be determined.

#### 6.1.4. Controlling parameters

Here, those values are entered for the two controllers, which are determinative according to the system to be controlled, such as:

- proportional band
- lead time
- lag time
- relay interval time
- maximum permissible rating
- dead band.

#### 6.1.5 System data

Here, the type of indication, type of program sequence and the digital in- and outputs are determined.

#### 6.1.6. Analogue inputs and outputs

The available additional analogue input can be configured within wide limits for an external nominal-value input (see page 30).

The two analogue outputs can be programmed in relation with the value to be represented, as well as with the range.

#### 6.1.7. Offset

In order to compensate a possible sensor error an offset can be determined for every input, which corrects the measurement over the entire range by this constant amount.

### 6.2. Adaptation within the protected range

## UNIVERSAL CONTROLLER TECON 202

The configuration level can be accessed by simultaneously pressing the "UP" and the "DOWN" key for 3 seconds.









In order to make changes a code must be known. Without this code the values can only be checked and not altered. The factory-set code = 0, though, it can be changed to any figure by the user.

The 7 data ranges are selected by means of the arrow keys (forward or backward) The operating level can be accessed again at any time by pressing the "PROG" key during 3 seconds . If no key is pressed for more than 60 seconds the unit automatically changes back to the operating level.

Pressing the "PROG" key for a short instant switches the display and the entry one step forward within a data range.

If the "PROG" key is pressed between 1 and 2 seconds the display and the entry are switched back one step.

### 6.2.1. Access to configuration

Step	Press key	Indication	Function
1	 simultaneous during 3 sec.		By entering the code defined by the user, (with new unit = 0) programming will be enabled. Without valid code the data can only be checked. This step is only necessary when data have to be altered.
2			The code is acknowledged and if correct, can now be readjusted. If the code was wrong these two steps are skipped.
3			
4			The code which was reprogrammed at step 3 is now valid. Now the required data range can be selected.

### 6.2.2. Selection of the data range

The data range is selected with the arrow keys (forward and backward)

































- ALA = alarm data
- SER = serial interfaces
- SEN = sensors
- PAR = control parameter
- SYS = system configuration
- A.OUT= analogue outputs
- OFF = offsets (correction of the actual-value measurement and the external nominal value)

## UNIVERSAL CONTROLLER TECON 202

The "PROG" key gives access to the data of the selected range.

The data are stored in the controller. It is recommendable to record these also in print. See the list of adjustment data, page 43.

### 6.3. Alarm data

Step	Press key	Indication	Function
1	 		Alarm data range.
2			Adjusting the maximum temperature for sensor 1.
3	 		If this temperature is exceeded the heating of controller 1 is switched off. An alarm is set off only when this has been programmed. Range : according to the set sensor.
4			Adjusting the minimum temperature for sensor 1.
5	 		If this temperature falls below the set limit the cooling of controller 1 is switched off. An alarm is set off only when this has been programmed. Range : according to the set sensor.
6			Adjusting the over temperature limit 1.
7	 		If the actual value exceeds the nominal value by this value an alarm is set off. Range : 0 - 99°C (over temperature = 0: alarm is switched off)
8			Setting the under temperature alarm limit 1.
9	 		If the actual value falls below the nominal value by this amount alarm is set off. Range : 0 - 99°C (undertemperature = 0: alarm is switched off)
10			Setting the alarm code for sensor 1.
11	 		For denotation see following table. Range : 0 - 4
12			Adjusting the maximum temperature of sensor 2.
13	 		When this temperature is exceeded the heating is switched off. The alarm is set off only when it has been programmed. The range depends on the selected sensor.

Step	Press key	Indication	Function															
14			Adjusting the minimum temperature of sensor 2.															
15			When the temperature falls below this value the cooling is switched off. Alarm is set off only when it has been programmed. The range depends on the selected sensor.															
16			Setting the over temperature alarm limit 2.															
17			When the actual value exceeds the nominal value by this amount alarm is set off. Range : 0 - 99°C. When 0 is entered the over temperature alarm 2 is switched off.															
18			Setting the under temperature alarm limit 2.															
19			When the actual value exceeds the nominal value by this amount alarm is set off. Range : 0 - 99°C. When 0 is entered the under temperature alarm 2 is switched off.															
20			Setting the alarm code for sensor 2.															
21			For denotation see following table. Range : 0 - 4															
22			Setting the alarm code 3.															
23			Range: 0 - 3 , denotation: <table border="1"> <thead> <tr> <th>Code</th> <th>power on condition</th> <th>program. end</th> </tr> </thead> <tbody> <tr> <td>0</td> <td>no alarm</td> <td>no alarm</td> </tr> <tr> <td>1</td> <td>alarm</td> <td>no alarm</td> </tr> <tr> <td>2</td> <td>no alarm</td> <td>alarm</td> </tr> <tr> <td>3</td> <td>alarm</td> <td>alarm</td> </tr> </tbody> </table>	Code	power on condition	program. end	0	no alarm	no alarm	1	alarm	no alarm	2	no alarm	alarm	3	alarm	alarm
Code	power on condition	program. end																
0	no alarm	no alarm																
1	alarm	no alarm																
2	no alarm	alarm																
3	alarm	alarm																
24			Setting the threshold temperature (temp. contact).															
25			If sensor 2 has been programmed the threshold relates to this, otherwise to sensor 1. Range : according to selected sensor															
26			End of the alarm data range. A new range can be selected with the arrow keys.															

## UNIVERSAL CONTROLLER TECON 202

### 6.3.1. Alarm code table for Code 1 and 2:

Code	Function	Indication	Acknowledge
0	Alarm is switched off	none	none
1	The alarm relay is open as long as the alarm conditions are fulfilled.	none	none
2	The alarm relay is open as long as the alarm conditions are fulfilled.	yes	only monitoring
3	The alarm relay is released when the alarm condition ensues and remains released until acknowledged.	yes	yes
4	The alarm relay is released when the alarm condition ensues. The alarm relay remains released until the alarm condition vanishes.	yes	only monitoring

### 6.3.2. Alarm types and indications in their sequence of priority

Alarm type	Indication	Alarm condition
1. Power on	P-on	power down
2. Sensor break	Sensor symbol	the relevant sensor does not supply a valid signal
3. Maximum value 1	$\wedge$ °C1	Value sensor 1 > programmed alarm value
4. Minimum value	$\_$ °C1	Value sensor 1 < min. alarm
5. Over temperature 1	$=$ °C1	Value sensor 1 exceeds nominal value by more than the programmed value
6. Undertemperature 1	$=$ °C1	Value sensor 1 falls below the nominal value by more than the programmed value
7. Maximum value 2	$\wedge$ °C2	Value sensor 2 > programmed alarm value
8. Minimum value 2	$\_$ °C2	Value sensor 2 < min. alarm
9. Over temperature 2	$=$ °C2	Value sensor 2 exceeds the nominal value by more than the programmed value
10. Undertemperature 2	$=$ °C2	Value sensor 2 falls below the nominal value by more than the programmed value
11. Program end	End	End of the running program
12. Serial interface	SEr 1	Time-out of the serial interface

6.3.3. Over- and under temperature alarm





















With both the values for over and under temperature limits set, a band around the setpoint is checked.

If the alarm code is 3 or 4, the controlled value must have been within this band, before an alarm can come up. If the setpoint is changed, this condition must be fulfilled again. With alarm code 1 or 2, the alarm occurs always if the controlled value is out of the checked band.

Examples for Alarm-Code > 2

Mode	without ramp	with ramp
1. Over- and under temperature set		
2. Over temperature set		
3. Under temperature set		

6.4. Serial interface

Step	Press key	Indication	Function
1	 		Range serial interface
2			Setting the unit address. Range: 0 - 31
3	 		
4			Setting the code of the 1st serial interface. For denotation see code table below.
5	 		
6			Setting the monitoring time of the 1st interface in seconds. If no message is identified at the interface after this interval (e.g. because of wire break) the control system switches off, the relay falls off and on the display "Ser.1" flashes.
7	 		Range : 0 - 1000 seconds. 0 = monitoring switched off.
8			End of range serial-interface. A new range can be selected with the arrow keys.























6.4.1. Code table for the serial interface

Value	Adr.	Function
0	--	off (no data are received or emitted)
1	99	master, emits nominal value 1 (Adr. 99 for internal use only)
2	--	not used
3	99	slave without reply, regards start/stop, nominal value
4	99	slave without reply, regards start/stop, nom. value = program. nom. value + master nom. value
5	99	slave without reply, regards start/stop, Progr. nr.
6-15	--	not used
16	0-31	Slave regards all commands and replies, intervention at controller possible
17	0-31	Slave regards all commands and replies, no intervention at controller possible























If the controller is operated with function code 16 or 17 and in combination with non-TECON units, we recommend to request the description "Serial standard interface of the TECON controllers".

6.5. Sensors





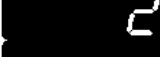

## UNIVERSAL CONTROLLER TECON 202

Step	Press key	Indication	Function																																							
1			Sensor range																																							
2			Adjusting the first sensor.																																							
3			<table style="width: 100%; border-collapse: collapse;"> <thead> <tr> <th style="text-align: left;">Sensor</th> <th style="text-align: left;">Range</th> <th style="text-align: left;">Lower display</th> </tr> <tr> <th colspan="3" style="border-top: 1px dashed black; border-bottom: 1px dashed black;"></th> </tr> </thead> <tbody> <tr> <td>NiCr-Ni (K)</td> <td>-200 - 1200 °C</td> <td>CA</td> </tr> <tr> <td>Fe-Co (J)</td> <td>-200 - 750 °C</td> <td>FEC0</td> </tr> <tr> <td>PtRh10% (S)</td> <td>0 - 1600 °C</td> <td>PT10</td> </tr> <tr> <td>PtRh13% (R)</td> <td>200 - 1600 °C</td> <td>PT13</td> </tr> <tr> <td>Pt100</td> <td>-200 - 750 °C</td> <td>P100</td> </tr> <tr> <td>Pt100 on 84-Ohm Z-Barrier, 2 wires</td> <td>-200 - 400 °C</td> <td>P184</td> </tr> <tr> <td>Pt100 on 84-Ohm Z-Barrier, 4 wires</td> <td>-200 - 400 °C</td> <td>P.184</td> </tr> <tr> <td>4-20 mA</td> <td>-200 - 2000 °C</td> <td>4-20</td> </tr> <tr> <td>0-20 mA</td> <td>-200 - 2000 °C</td> <td>0-20</td> </tr> <tr> <td>PtRh 18% (B)</td> <td>200 - 1800 °C</td> <td>PT18</td> </tr> <tr> <td>Nicrosil-Nisil (N)</td> <td>-200 - 1200 °C</td> <td>NISI</td> </tr> </tbody> </table>	Sensor	Range	Lower display				NiCr-Ni (K)	-200 - 1200 °C	CA	Fe-Co (J)	-200 - 750 °C	FEC0	PtRh10% (S)	0 - 1600 °C	PT10	PtRh13% (R)	200 - 1600 °C	PT13	Pt100	-200 - 750 °C	P100	Pt100 on 84-Ohm Z-Barrier, 2 wires	-200 - 400 °C	P184	Pt100 on 84-Ohm Z-Barrier, 4 wires	-200 - 400 °C	P.184	4-20 mA	-200 - 2000 °C	4-20	0-20 mA	-200 - 2000 °C	0-20	PtRh 18% (B)	200 - 1800 °C	PT18	Nicrosil-Nisil (N)	-200 - 1200 °C	NISI
Sensor	Range	Lower display																																								
NiCr-Ni (K)	-200 - 1200 °C	CA																																								
Fe-Co (J)	-200 - 750 °C	FEC0																																								
PtRh10% (S)	0 - 1600 °C	PT10																																								
PtRh13% (R)	200 - 1600 °C	PT13																																								
Pt100	-200 - 750 °C	P100																																								
Pt100 on 84-Ohm Z-Barrier, 2 wires	-200 - 400 °C	P184																																								
Pt100 on 84-Ohm Z-Barrier, 4 wires	-200 - 400 °C	P.184																																								
4-20 mA	-200 - 2000 °C	4-20																																								
0-20 mA	-200 - 2000 °C	0-20																																								
PtRh 18% (B)	200 - 1800 °C	PT18																																								
Nicrosil-Nisil (N)	-200 - 1200 °C	NISI																																								
4			This indication only appears when a current input is used for sensor.																																							
5			Adjusting the lower limit of the current input. Range : -200 to 2000°C																																							
6			This indication only appears when a current input is used for sensor.																																							
7			Adjusting the upper limit of the current input. Range : -200 to 2000°C																																							
8			Adjusting the lower limit of the 1st control range. This control range limits the nominal-value input.																																							
9																																										
10			Adjusting the upper limit of the 1st control range. This control range limits the nominal-value input.																																							
11																																										





























## UNIVERSAL CONTROLLER TECON 202

Step	Press key	Indication	Function																																							
12			Adjustment of the filter constant for sensor 1 ( = max. temperature change per second ). When value 9.9 is set a lowpass filter of the 1st order is programmed with the time constant 8s. Range : 0.0 - 9.9 °C/sec. (0=filter switched off)																																							
13																																										
14			Adjusting the second sensor.																																							
15			<table style="width: 100%; border-collapse: collapse;"> <thead> <tr> <th style="text-align: left;">Sensor</th> <th style="text-align: left;">Range</th> <th style="text-align: left;">lower indication</th> </tr> <tr> <th colspan="3" style="border-top: 1px dashed black; border-bottom: 1px dashed black;"></th> </tr> </thead> <tbody> <tr> <td>NiCr-Ni (K)</td> <td>-200 - 1200 °C</td> <td>CA</td> </tr> <tr> <td>Fe-Co (J)</td> <td>-200 - 750 °C</td> <td>FEC<sub>o</sub></td> </tr> <tr> <td>PtRh10% (S)</td> <td>0 - 1600 °C</td> <td>PT10</td> </tr> <tr> <td>PtRh13% (R)</td> <td>200 - 1600 °C</td> <td>PT13</td> </tr> <tr> <td>Pt100</td> <td>-200 - 750 °C</td> <td>P100</td> </tr> <tr> <td>Pt100 on 84-Ohm Z-Barrier, 2 wires</td> <td>-200 - 400 °C</td> <td>P184</td> </tr> <tr> <td>Pt100 on 84-Ohm Z-Barrier, 4 wires</td> <td>-200 - 400 °C</td> <td>P.184</td> </tr> <tr> <td>4-20 mA</td> <td>-200 - 2000 °C</td> <td>4-20</td> </tr> <tr> <td>0-20 mA</td> <td>-200 - 2000 °C</td> <td>0-20</td> </tr> <tr> <td>PtRh18% (B)</td> <td>200 - 1800 °C</td> <td>PT18</td> </tr> <tr> <td>Nicrosil-Nisil (N)</td> <td>-200 - 1200 °C</td> <td>NISI</td> </tr> </tbody> </table>	Sensor	Range	lower indication				NiCr-Ni (K)	-200 - 1200 °C	CA	Fe-Co (J)	-200 - 750 °C	FEC <sub>o</sub>	PtRh10% (S)	0 - 1600 °C	PT10	PtRh13% (R)	200 - 1600 °C	PT13	Pt100	-200 - 750 °C	P100	Pt100 on 84-Ohm Z-Barrier, 2 wires	-200 - 400 °C	P184	Pt100 on 84-Ohm Z-Barrier, 4 wires	-200 - 400 °C	P.184	4-20 mA	-200 - 2000 °C	4-20	0-20 mA	-200 - 2000 °C	0-20	PtRh18% (B)	200 - 1800 °C	PT18	Nicrosil-Nisil (N)	-200 - 1200 °C	NISI
Sensor	Range	lower indication																																								
NiCr-Ni (K)	-200 - 1200 °C	CA																																								
Fe-Co (J)	-200 - 750 °C	FEC <sub>o</sub>																																								
PtRh10% (S)	0 - 1600 °C	PT10																																								
PtRh13% (R)	200 - 1600 °C	PT13																																								
Pt100	-200 - 750 °C	P100																																								
Pt100 on 84-Ohm Z-Barrier, 2 wires	-200 - 400 °C	P184																																								
Pt100 on 84-Ohm Z-Barrier, 4 wires	-200 - 400 °C	P.184																																								
4-20 mA	-200 - 2000 °C	4-20																																								
0-20 mA	-200 - 2000 °C	0-20																																								
PtRh18% (B)	200 - 1800 °C	PT18																																								
Nicrosil-Nisil (N)	-200 - 1200 °C	NISI																																								
16			This indication appears only when a current input is used for the sensor.																																							
17			Setting the lower limit of the current input. Range : -200 to 2000°C																																							
18			This indication appears only when a current input is used for the sensor.																																							
19			Setting the upper limit of the current input. Range : -200 to 2000°C																																							
20			Setting the lower limit of the 2nd control range. This control range limits the nominal-value input.																																							
21																																										
22			The upper limit of the 2nd control range is being set. This control range limits the nominal-value input.																																							
23																																										











































## UNIVERSAL CONTROLLER TECON 202

Step	Press key	Indication	Function
24			Adjustment of the filter constant for sensor 2 ( = max. temperature change per second ). When value 9.9 is set a lowpass filter of the 1st order is programmed with the time constant 8s. Range : 0.0 - 9.9 °C/sec. (0=filter switched off)
25	 		
26			End of sensor range. A new range can be selected with the arrow keys.

### 6.6. Controller parameters









Step	Press key	Indication	Function
1	 		Parameter range.
2			Setting the proportional band for controller 1. Within the proportional band the output is controlled in proportion to the deviation between nominal and actual value. Range : 0 - 999°C (0 = on/off controller)
3	 		
4			Setting the lag time 1 (integral). With the lag time the deviation caused by the proportional control is compensated. Range : 0 - 999 seconds (0=no integral action).
5	 		
6			Setting the lead time (differential) 1. The lead time effects in switching off before the nominal value is reached, thus avoiding overshoot. Range : 0 - 999 seconds (0= no differential action).
7	 		
8			Setting the relay interval-time 1. With quasi-proportional control the output with constant interval time, is effected by changing the pulse-pause ratio. Range : 1 - 999 seconds.
9	 		
10			Setting the maximum output 1 (in %). The output rating can be limited so as to obtain a smoother controlling effect. Range : 10 - 100%
11	 		

## UNIVERSAL CONTROLLER TECON 202



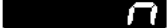









Step	Press key	Indication	Function
12			Setting the proportional band for controller 2. Within the proportional band the output is controlled in proportion to the deviation between nominal and actual value.
13	 		Range : 0 - 999°C (0 = on/off controller)
14			Setting the lag time 2 (integral). With the lag time the deviation caused by the proportional control is compensated.
15	 		Range : 0 - 999 seconds (0=no integral action)..
16			Setting the lead time (differential) 2. The lead time effects in switching off before the nominal value is reached, thus avoiding overshoot
17	 		Range : 0 - 999 seconds (0= no differential action).
18			Setting the relay interval-time 2. With quasi-proportional control with constant interval time, the output is controlled by changing the pulse-pause ratio.
19	 		Range : 1 - 999 seconds.
20			Setting the maximum output 2 (in %). The output rating can be limited so as to obtain a smoother controlling effect.
21	 		Range : 10 - 100%
22			Setting the dead band. Within this band, between heating and cooling, neither heating nor cooling is active (only with controller Code 0 or 1).
23	 		Range : 0 - 99.9°C
24			Setting the nominal-value offset. With controller Code 6 or 7 the nominal value of the 2nd controller is offset from the 1st controller by the amount entered here.
25	 		Range : -99.9 to 99.9°C.
26			Setting the adjustment time range for servo motors. With controllers Code 10 or 11 the response time of the motor must be entered. This influences the duration of the control pulses.
27	 		Range : 1 - 999 seconds.
28			End of the parameter range. A new range can be selected with the arrow keys.







**6.7. System configuration**

On this controller the indication, the program mode, the digital in- and outputs and the type of controller can be adapted to the requirements of the user.























Step	Press key	Indication	Function																																				
1			System-data range.																																				
2			Setting the display code. Range : 0 - 7																																				
3			<table border="1"> <thead> <tr> <th>Code</th> <th>Resolution</th> <th>Upper display</th> <th>Lower display</th> </tr> </thead> <tbody> <tr> <td>0</td> <td>1°C</td> <td>actual value 1</td> <td>nominal value 1</td> </tr> <tr> <td>1</td> <td>0.1°C</td> <td>actual value 1</td> <td>nominal value 1</td> </tr> <tr> <td>2</td> <td>1°C</td> <td>actual value 1</td> <td>actual value 2 (1)</td> </tr> <tr> <td>3</td> <td>0.1°C</td> <td>actual value 1</td> <td>actual value 2 (1)</td> </tr> <tr> <td>4</td> <td>1°C</td> <td>actual value 2</td> <td>nominal value 2 (2)</td> </tr> <tr> <td>5</td> <td>0.1°C</td> <td>actual value 2</td> <td>nominal value 2 (2)</td> </tr> <tr> <td>6</td> <td>1°C</td> <td colspan="2">no automatic switch-over</td> </tr> <tr> <td>7</td> <td>0.1°C</td> <td colspan="2">to normal indication.</td> </tr> </tbody> </table> <p>(1): Indication only when sensor is fitted (2): Only with controller code 6 or 7</p>	Code	Resolution	Upper display	Lower display	0	1°C	actual value 1	nominal value 1	1	0.1°C	actual value 1	nominal value 1	2	1°C	actual value 1	actual value 2 (1)	3	0.1°C	actual value 1	actual value 2 (1)	4	1°C	actual value 2	nominal value 2 (2)	5	0.1°C	actual value 2	nominal value 2 (2)	6	1°C	no automatic switch-over		7	0.1°C	to normal indication.	
Code	Resolution	Upper display	Lower display																																				
0	1°C	actual value 1	nominal value 1																																				
1	0.1°C	actual value 1	nominal value 1																																				
2	1°C	actual value 1	actual value 2 (1)																																				
3	0.1°C	actual value 1	actual value 2 (1)																																				
4	1°C	actual value 2	nominal value 2 (2)																																				
5	0.1°C	actual value 2	nominal value 2 (2)																																				
6	1°C	no automatic switch-over																																					
7	0.1°C	to normal indication.																																					
4			Setting the program sequence code																																				
5			<table border="1"> <thead> <tr> <th>Code</th> <th>Denotation</th> </tr> </thead> <tbody> <tr> <td>0</td> <td>Dwell time begins when the setpoint ramp = setpoint dwell time</td> </tr> <tr> <td>1</td> <td>Dwell time begins when the setpoint ramp = setpoint dwell time and actual value = setpoint ±2°C.</td> </tr> <tr> <td>2</td> <td>Dwell time begins when the setpoint ramp = setpoint dwell time and actual value within alarm limits dwell time .</td> </tr> <tr> <td>3</td> <td>Dwell time begins with the program sector.</td> </tr> <tr> <td>4</td> <td>The ramp begins at the momentary setpoint. Dwell time begins when the setpoint ramp = setpoint dwell time.</td> </tr> <tr> <td>5</td> <td>As code 1 but at ramp = 0 begins dwell time immediately.</td> </tr> <tr> <td>6</td> <td>As code 2 but at ramp = 0 begins dwell time immediately.</td> </tr> </tbody> </table>	Code	Denotation	0	Dwell time begins when the setpoint ramp = setpoint dwell time	1	Dwell time begins when the setpoint ramp = setpoint dwell time and actual value = setpoint ±2°C.	2	Dwell time begins when the setpoint ramp = setpoint dwell time and actual value within alarm limits dwell time .	3	Dwell time begins with the program sector.	4	The ramp begins at the momentary setpoint. Dwell time begins when the setpoint ramp = setpoint dwell time.	5	As code 1 but at ramp = 0 begins dwell time immediately.	6	As code 2 but at ramp = 0 begins dwell time immediately.																				
Code	Denotation																																						
0	Dwell time begins when the setpoint ramp = setpoint dwell time																																						
1	Dwell time begins when the setpoint ramp = setpoint dwell time and actual value = setpoint ±2°C.																																						
2	Dwell time begins when the setpoint ramp = setpoint dwell time and actual value within alarm limits dwell time .																																						
3	Dwell time begins with the program sector.																																						
4	The ramp begins at the momentary setpoint. Dwell time begins when the setpoint ramp = setpoint dwell time.																																						
5	As code 1 but at ramp = 0 begins dwell time immediately.																																						
6	As code 2 but at ramp = 0 begins dwell time immediately.																																						



















## UNIVERSAL CONTROLLER TECON 202

Step	Press key	Indication	Function																												
6			Setting the code for the digital input. Range : 0 - 5																												
7			<table style="width: 100%; border-collapse: collapse;"> <thead> <tr> <th style="text-align: left;">Code</th> <th style="text-align: left;">Function</th> </tr> </thead> <tbody> <tr> <td>0</td> <td>Control function off when ext., contact closed.</td> </tr> <tr> <td>1</td> <td>Control function on when ext. contact closed. Control function off when ext. contact open</td> </tr> <tr> <td>2</td> <td>Control function starts and stops with ext. pulse.</td> </tr> <tr> <td>3</td> <td>Program starts and switches further with ext. pulse.</td> </tr> <tr> <td>4</td> <td>Program run interrupts if ext. contact is closed</td> </tr> <tr> <td>5</td> <td>As code 1 but start/stop key is operating.</td> </tr> </tbody> </table>	Code	Function	0	Control function off when ext., contact closed.	1	Control function on when ext. contact closed. Control function off when ext. contact open	2	Control function starts and stops with ext. pulse.	3	Program starts and switches further with ext. pulse.	4	Program run interrupts if ext. contact is closed	5	As code 1 but start/stop key is operating.														
Code	Function																														
0	Control function off when ext., contact closed.																														
1	Control function on when ext. contact closed. Control function off when ext. contact open																														
2	Control function starts and stops with ext. pulse.																														
3	Program starts and switches further with ext. pulse.																														
4	Program run interrupts if ext. contact is closed																														
5	As code 1 but start/stop key is operating.																														
8			Setting the code for the digital output. Range: 0 - 11																												
9			<table style="width: 100%; border-collapse: collapse;"> <thead> <tr> <th style="text-align: left;">Code table</th> <th style="text-align: left;">Polarity:</th> <th style="text-align: left;">+</th> <th style="text-align: left;">-</th> </tr> </thead> <tbody> <tr> <td>Impulse at program end</td> <td></td> <td style="text-align: center;">0</td> <td style="text-align: center;">1</td> </tr> <tr> <td>Impulse at start and stop</td> <td></td> <td style="text-align: center;">2</td> <td style="text-align: center;">3</td> </tr> <tr> <td>Impulse at sector beginning</td> <td></td> <td style="text-align: center;">4</td> <td style="text-align: center;">5</td> </tr> <tr> <td>Impulse at beginning dwell time</td> <td></td> <td style="text-align: center;">6</td> <td style="text-align: center;">7</td> </tr> <tr> <td>Temperature threshold</td> <td></td> <td style="text-align: center;">8</td> <td style="text-align: center;">9</td> </tr> <tr> <td>controlling on</td> <td></td> <td style="text-align: center;">10</td> <td style="text-align: center;">11</td> </tr> </tbody> </table>	Code table	Polarity:	+	-	Impulse at program end		0	1	Impulse at start and stop		2	3	Impulse at sector beginning		4	5	Impulse at beginning dwell time		6	7	Temperature threshold		8	9	controlling on		10	11
Code table	Polarity:	+	-																												
Impulse at program end		0	1																												
Impulse at start and stop		2	3																												
Impulse at sector beginning		4	5																												
Impulse at beginning dwell time		6	7																												
Temperature threshold		8	9																												
controlling on		10	11																												
10			Setting the code for the current outputs. Range: 0 - 7																												
11			<table style="width: 100%; border-collapse: collapse;"> <thead> <tr> <th style="text-align: left;">Code</th> <th style="text-align: left;">Function</th> </tr> </thead> <tbody> <tr> <td>0</td> <td>0-100% equivalent to 4 - 20 mA</td> </tr> <tr> <td>1</td> <td>0-100% equivalent to 0 - 20 mA</td> </tr> <tr> <td>2</td> <td>-100 -100% equivalent to 4 - 20 mA</td> </tr> <tr> <td>3</td> <td>-100 -100% equivalent to 0 - 20 mA</td> </tr> <tr> <td>4</td> <td>0-100% equivalent to 20 - 4 mA</td> </tr> <tr> <td>5</td> <td>0-100% equivalent to 20 - 0 mA</td> </tr> <tr> <td>6</td> <td>-100 -100% equivalent to 20 - 4 mA</td> </tr> <tr> <td>7</td> <td>-100 -100% equivalent to 20 - 0 mA</td> </tr> </tbody> </table>	Code	Function	0	0-100% equivalent to 4 - 20 mA	1	0-100% equivalent to 0 - 20 mA	2	-100 -100% equivalent to 4 - 20 mA	3	-100 -100% equivalent to 0 - 20 mA	4	0-100% equivalent to 20 - 4 mA	5	0-100% equivalent to 20 - 0 mA	6	-100 -100% equivalent to 20 - 4 mA	7	-100 -100% equivalent to 20 - 0 mA										
Code	Function																														
0	0-100% equivalent to 4 - 20 mA																														
1	0-100% equivalent to 0 - 20 mA																														
2	-100 -100% equivalent to 4 - 20 mA																														
3	-100 -100% equivalent to 0 - 20 mA																														
4	0-100% equivalent to 20 - 4 mA																														
5	0-100% equivalent to 20 - 0 mA																														
6	-100 -100% equivalent to 20 - 4 mA																														
7	-100 -100% equivalent to 20 - 0 mA																														





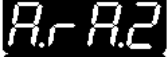







Step	Press key	Indication	Function																																																				
12			Setting the controller code. Range: 0 - 7																																																				
13			<table border="1"> <thead> <tr> <th>Code</th> <th>Controller 1</th> <th>Controller 2</th> <th>Sensor 2</th> </tr> </thead> <tbody> <tr><td>0</td><td>heating</td><td>cooling</td><td>not fitted</td></tr> <tr><td>1</td><td>heating</td><td>cooling</td><td>monitoring</td></tr> <tr><td>2</td><td>heating</td><td>dig.out</td><td>not fitted</td></tr> <tr><td>3</td><td>heating</td><td>dig.out</td><td>monitoring</td></tr> <tr><td>4</td><td>cooling</td><td>dig.out</td><td>not fitted</td></tr> <tr><td>5</td><td>cooling</td><td>dig.out</td><td>monitoring</td></tr> <tr><td>6</td><td>heating</td><td>heating</td><td>controller 2</td></tr> <tr><td>7</td><td>cooling</td><td>cooling</td><td>controller 2</td></tr> <tr><td>8</td><td colspan="2">2-step controller</td><td>not fitted</td></tr> <tr><td>9</td><td colspan="2">2-step controller</td><td>monitoring</td></tr> <tr><td>10</td><td colspan="2">motor step contr.</td><td>not fitted</td></tr> <tr><td>11</td><td colspan="2">motor step contr.</td><td>monitoring</td></tr> </tbody> </table> <p>Controller code 6 + 7: 2-zone-controller : 2 individual controllers operate with the same nominal value. With the parameter "Offset nominal value controller 2" the nominal value of controller 2 can be offset by a fixed value. (s. Control parameter step 24 , page 26 )</p>	Code	Controller 1	Controller 2	Sensor 2	0	heating	cooling	not fitted	1	heating	cooling	monitoring	2	heating	dig.out	not fitted	3	heating	dig.out	monitoring	4	cooling	dig.out	not fitted	5	cooling	dig.out	monitoring	6	heating	heating	controller 2	7	cooling	cooling	controller 2	8	2-step controller		not fitted	9	2-step controller		monitoring	10	motor step contr.		not fitted	11	motor step contr.		monitoring
Code	Controller 1	Controller 2	Sensor 2																																																				
0	heating	cooling	not fitted																																																				
1	heating	cooling	monitoring																																																				
2	heating	dig.out	not fitted																																																				
3	heating	dig.out	monitoring																																																				
4	cooling	dig.out	not fitted																																																				
5	cooling	dig.out	monitoring																																																				
6	heating	heating	controller 2																																																				
7	cooling	cooling	controller 2																																																				
8	2-step controller		not fitted																																																				
9	2-step controller		monitoring																																																				
10	motor step contr.		not fitted																																																				
11	motor step contr.		monitoring																																																				
14			End of the system range. A new range can be selected with the arrow keys.																																																				

6.8. Analogue inputs and outputs

Step	Press key	Indication	Function
1	 		Range analogue inputs and outputs.
2			Setting of the analogue input. ( External nominal-value input.) Range: 0 - 5
3	 		Code      Range ----- 0      Nominal value input switched off 1      1 mV/°C 2      10 mV/°C 3      0 - 10 V 4      4 - 20 mA * 5      0 - 20 mA * * : Connect external shunt resistor 100R
4			Setting of the lower range limit of the analogue input. Range: -200 to 2000°C.
5	 		This indication appears only when range code 3 - 5 has been selected.
6			Setting of the upper range limit of the analogue input. Range: -200 to 2000°C.
7	 		This indication appears only when range code 3 - 5 has been selected
8			Setting of the code for the 1st analogue output. Range: 0 - 7
9	 		Code      analogue value ----- 0      actual value 1 1      actual value 2 2      nominal value 1 3      nominal value 2 4      output 1 5      output 2 6      actual value 1 - nominal value 1 7      actual value 2 - nominal value 2

Step	Press key	Indication	Function																					
10			Setting the range of the 1st analogue output.																					
11			<table border="1"> <thead> <tr> <th>Code</th> <th>Range</th> <th>Availability</th> </tr> </thead> <tbody> <tr> <td>0</td> <td>10mV/°C</td> <td></td> </tr> <tr> <td>1</td> <td>1 mV/°C</td> <td>202 -XX0X / XX2X</td> </tr> <tr> <td>2</td> <td>0 - 10V</td> <td>(see page 41)</td> </tr> <tr> <td>3</td> <td>0 - 2 V</td> <td></td> </tr> <tr> <td>4</td> <td>4 - 20 mA</td> <td>202 - XX1X / XX3X</td> </tr> <tr> <td>5</td> <td>0 - 20 mA</td> <td>(see page 41)</td> </tr> </tbody> </table>	Code	Range	Availability	0	10mV/°C		1	1 mV/°C	202 -XX0X / XX2X	2	0 - 10V	(see page 41)	3	0 - 2 V		4	4 - 20 mA	202 - XX1X / XX3X	5	0 - 20 mA	(see page 41)
Code	Range	Availability																						
0	10mV/°C																							
1	1 mV/°C	202 -XX0X / XX2X																						
2	0 - 10V	(see page 41)																						
3	0 - 2 V																							
4	4 - 20 mA	202 - XX1X / XX3X																						
5	0 - 20 mA	(see page 41)																						
12			Setting the lower range limit of the 1st analogue output.																					
13			<p>Range: -200 to 2000°C.</p> <p>This indication appears only when range code 2 - 5 has been selected. The unit of the output signal Code 4 and 5 is % (-100 to 100).</p>																					
14			Setting the upper range limit of the 1st analogue output.																					
15			<p>Range: -200 to 2000°C.</p> <p>This indication appears only when range code 2 - 5 has been selected. The unit of the output signal Code 4 and 5 is % (-100 to 100).</p>																					
16			Setting the code for the 2nd analogue output.																					
17			<p>Range: 0 - 7</p> <table border="1"> <thead> <tr> <th>Code</th> <th>analogue value</th> </tr> </thead> <tbody> <tr> <td>0</td> <td>actual value 1</td> </tr> <tr> <td>1</td> <td>actual value 2</td> </tr> <tr> <td>2</td> <td>nominal value 1</td> </tr> <tr> <td>3</td> <td>nominal value 2</td> </tr> <tr> <td>4</td> <td>output 1</td> </tr> <tr> <td>5</td> <td>output 2</td> </tr> <tr> <td>6</td> <td>actual value 1 - nominal value 1</td> </tr> <tr> <td>7</td> <td>actual value 2 - nominal value 2</td> </tr> </tbody> </table>	Code	analogue value	0	actual value 1	1	actual value 2	2	nominal value 1	3	nominal value 2	4	output 1	5	output 2	6	actual value 1 - nominal value 1	7	actual value 2 - nominal value 2			
Code	analogue value																							
0	actual value 1																							
1	actual value 2																							
2	nominal value 1																							
3	nominal value 2																							
4	output 1																							
5	output 2																							
6	actual value 1 - nominal value 1																							
7	actual value 2 - nominal value 2																							
18			Setting the range for the 2nd analogue output.																					
19			<table border="1"> <thead> <tr> <th>Code</th> <th>Range</th> <th>Availability</th> </tr> </thead> <tbody> <tr> <td>0</td> <td>10mV/°C</td> <td></td> </tr> <tr> <td>1</td> <td>1 mV/°C</td> <td>202 -XX0X / XX1X</td> </tr> <tr> <td>2</td> <td>0 - 10V</td> <td>(see page 41)</td> </tr> <tr> <td>3</td> <td>0 - 2 V</td> <td></td> </tr> <tr> <td>4</td> <td>4 - 20 mA</td> <td>202 - XX2X / XX3X</td> </tr> <tr> <td>5</td> <td>0 - 20 mA</td> <td>(see page 41)</td> </tr> </tbody> </table>	Code	Range	Availability	0	10mV/°C		1	1 mV/°C	202 -XX0X / XX1X	2	0 - 10V	(see page 41)	3	0 - 2 V		4	4 - 20 mA	202 - XX2X / XX3X	5	0 - 20 mA	(see page 41)
Code	Range	Availability																						
0	10mV/°C																							
1	1 mV/°C	202 -XX0X / XX1X																						
2	0 - 10V	(see page 41)																						
3	0 - 2 V																							
4	4 - 20 mA	202 - XX2X / XX3X																						
5	0 - 20 mA	(see page 41)																						







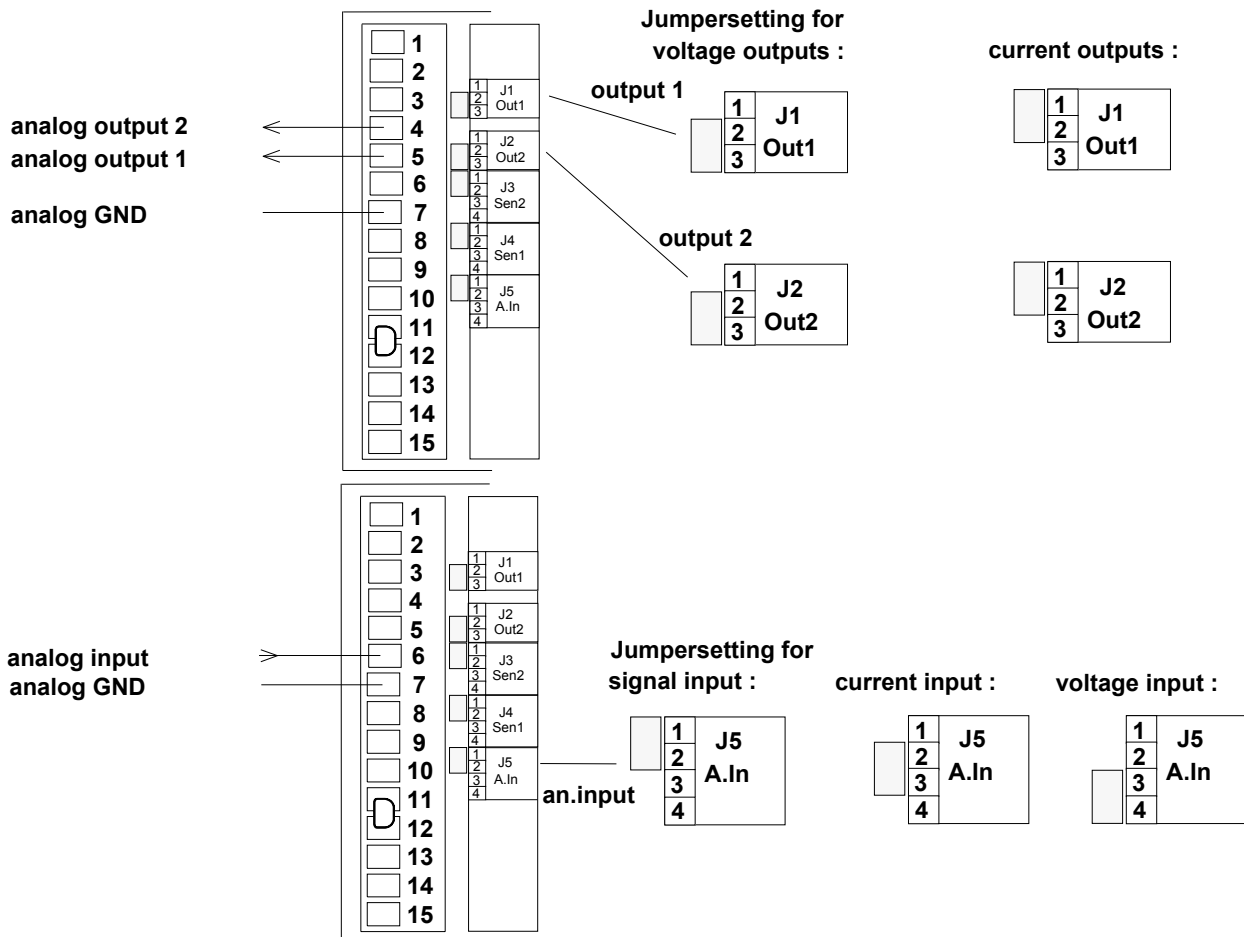













## UNIVERSAL CONTROLLER TECON 202

Step	Press key	Indication	Function
20			Setting the range limit of the 2nd analogue output. Range : -200 to 2000°C.
21	 		This indication appears only when range code 2 - 5 has been selected. The unit of the output signal Code 4 and 5 is % (-100 to 100).
22			Setting the upper range limit of the 2nd analogue output. Range: -200 to 2000°C.
23	 		This indication appears only when range code 2 - 5 has been selected. The unit of the output signal Code 4 and 5 is % (-100 to 100).
24			End of the range for analogue inputs and outputs. A new range can be selected with the arrow keys.

### 6.8.1. Jumper settings for analog input and outputs :



6.9. Offsets

Step	Press key	Indication	Function
1	 		Offset range.
2			Setting offset 1. ( Sensor 1)
3	 		Range: -99.9 to +99.9°C.
4			Setting offset 2. ( Sensor 2 )
5	 		Range: -99.9 to +99.9°C.
6			Setting offset 3. ( ext. nominal-value input or analogue input)
7	 		Range: -99.9 to +99.9 °C.
8			End of the offset range.

## 7. Program example

### 7.1. Needed temperature profile

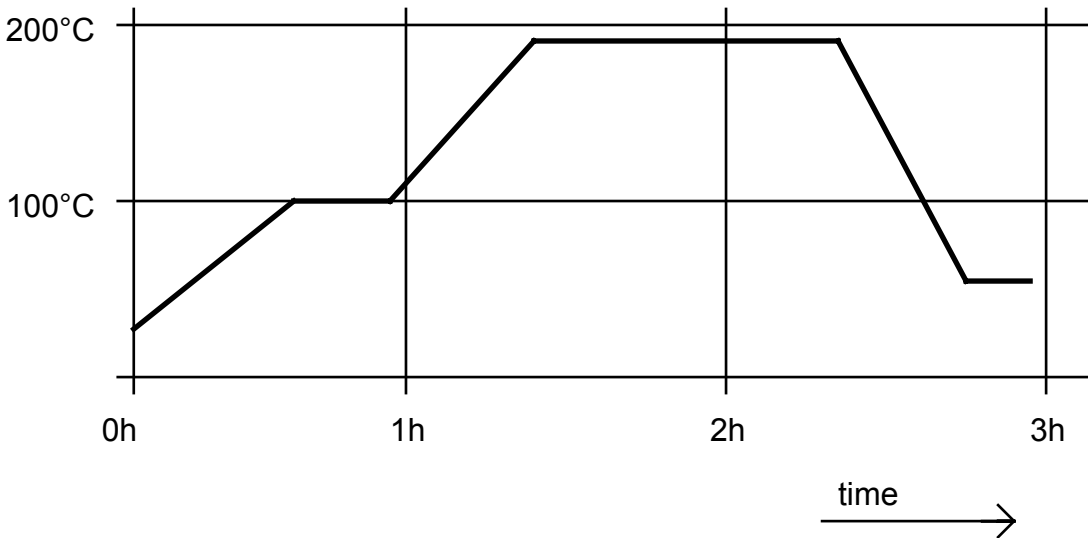









































- sector 1: Ramp with 150°C/h at 100°C, holding 30 min.
- sector 2: Ramp with 200°C/h at 180°C, holding 1h
- sector 3: Ramp with 400°C/h at 50°C, holding 15 min. and turn off



















This program must be saved as number 2. The sectors 3-7 must be reserved for other programs.

### 7.2. Program input

Step	Press key	Indication	Function
1			Calling the programming level and input of the code for the programming (new unit = 0).
simultaneous during 3sec.			
2			Acknowledge the code.
3			With the arrow keys the sector 2 is selected.
4			

Step	Press key	Indication	Function
5			Set the dwell temperature 100°C .
6	 		
7			Set the dwell time 30 min.
8	 		
9			Set the ramp 150°C/h .
10	 		
11			The following sector 8 is set.
12	 		
13			Set the dwell temperature 180°C .
14	 		
15			Set the dwell time 1h .
16	 		
17			Set the ramp 200°C/h .
18	 		
19			The following sector 9 is set..
20	 		

## UNIVERSAL CONTROLLER TECON 202

Step	Press key	Indication	Function
21			Set the dwell temperature 50°C.
22	 		
23			Set the dwell time 15 min.
24	 		
25			Set the ramp 400°C/h .
26	 		
27			The following sector 0 is set.
28	 		
29	 during 3s		End of programming. Nominal and actual value is displayed again.

The program can be started only with number 2. If the system is not able to cool and code 1 or 2 is set as program code (see System configuration page 27) it is possible that the dwell time of sector 9 is running after a long cooling time or not at all.

## 8. Serial interface

### 8.1. General

The TECON 200 controller series are standard fitted with an RS 485 interface, which allows the connecting up of several controllers, thus simplifying their operation. In this case one controller is programmed as master and all the others as slaves. The connected slaves, according to preselection, do more or less the same as the master. Thus, only the master has to be operated.

The operating performance of the controllers is determined by the code "SER1". This code is described in Chapter "Adapting the controller" under "serial interface". One of the connected controllers is made the master by setting its code on 1. This controller now continually sends its data to all the other connected controllers. These must have a code set between 3 and 5 so that they do not reply. It is important that only one controller is emitting as master and all others are receiving, because otherwise there will be a disarray of emitting units on the common line.

The slaves can be connected to the master in 2 manners:

Code 3 has the effect that the slaves are switched off together with the master, though do not take over its nominal value, but only its program section. This is of importance when controllers which do not control the same value, have to operate together, for instance temperature controllers together with pressure controllers. Here, the nominal value of the temperature controller does not make sense for the pressure controller. On the other hand, a temperature program and a pressure program can run simultaneously.

Neither master nor slaves require an address. Therefore, it is irrelevant which value is shown at the address (Adr.). Internally master and slaves use the address 99 for their data exchange. However, the alarm time can be used to switch off the slaves which have no longer a connection with the master in the event of a defect in the data transfer from the slaves, and to give an alarm message.

### 8.2. Operation with higher ranking control unit:

If the controller is operated as slave of a higher ranking control system, e.g. a PC, the code has to be set to 16 or 17 and each unit should have a different address. This, to make sure that only one controller is polled at a time and that no further message is given as long as the reply has not been received completely.

Contrary to master-slave operation, always only the addressed controller subjects to the commands of the master, i.e. every connected controller has to be operated individually, unless the master uses address 99. This is observed by all connected controllers also when code 16 or 17 is given.

TECON offers various programs for operation of units with a PC so as to optimise, document and monitor control systems.

## UNIVERSAL CONTROLLER TECON 202

Example: Master-slave operation of 3 controllers.

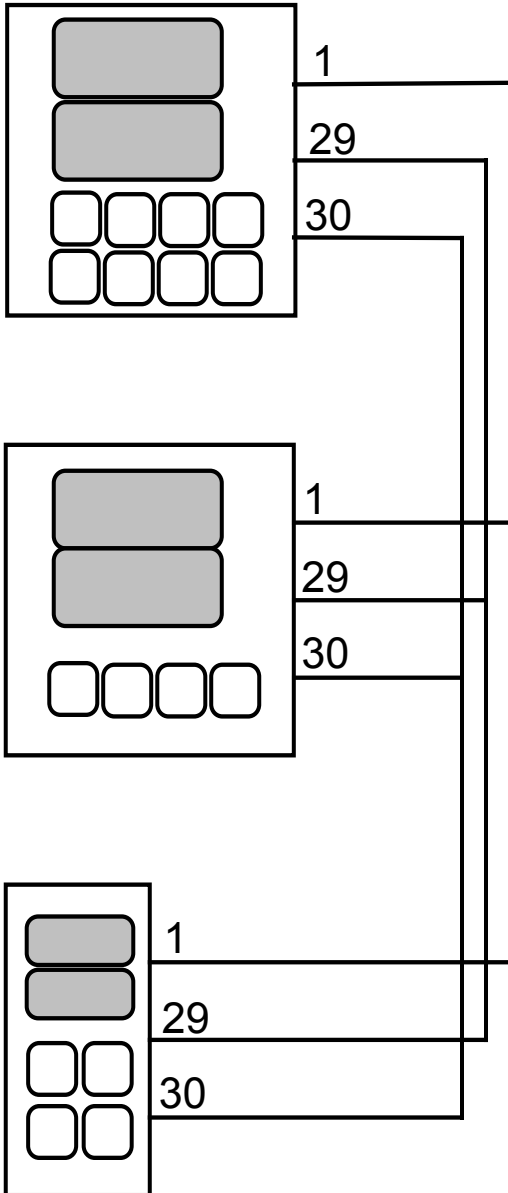

Master: TECON 230

Data of the serial interface:

Adr.: 0

Ser.1: 1

Alarm: 0

Function:

Only this controller is operated.

Slave 1: TECON 231 heating / cooling

Data of the serial interface:

Adr.: 0

Ser.1: 3

Alarm: 10

Function:

This slave starts and stops with the master. It controls the same nominal value. 10 seconds after termination of the connection with the master it stops.

Slave 2: TECON 202, heating/heating

Data of the serial interface:

Adr.: 0

Ser.1: 5

Alarm: 0

Function:

This slave starts and stops with the master and it is always in the same program section as the master. After disconnection it continues running with its own program.

Maximum number of controllers

32

Maximum conductor length

1000 m

Conductor cross-section:

0.5 - 1mm<sup>2</sup>

( long lines to be screened, screen onto PE)

## 9. Error messages, faults

### 9.1. Error messages of the controller

When the controller is switched on it carries out various self-tests. If an error is found an error message is given.

In the event of errors "SYST" appears on the upper display and the lower display shows "Err" and a number. The numbers have following denotation:

Indication	Cause	Remedy
Err1	Data loss	Press Start/Stop button. The controller is initialised. The data entered by the user are erased and have to be re-entered.
Err2	Memory fault int. RAM	Switch controller off and on again.
Err3	Fault in the EEPROM	Switch controller off and on again.
Err4	Fault in the program memory	Switch controller off and on again.
Err5	Fault in the AD-converter	Switch controller off and on again.
Err6	Program is not compatible ( Illegal manipulation on the controller.)	Press the Start/Stop key. The controller is initialised. The data entered by the user are erased and have to be re-entered.
Err7	The controller is not calibrated	Press the Start / Stop key. Although the controller can operate, the inputs and outputs are no longer sufficiently accurate.

If the error message appears repeatedly the unit will have to be sent to the manufacturers for repair.

### 9.2. Faults during operation

#### 9.2.1. The controller cannot be started.

The controller has been programmed for external start/stop. See Chapter 6. System data level, digital input or serial interface.

#### 9.2.2. Actual-value indication

Die actual-value indication flashes with the indication of the programmed sensor:

The sensor is not connected correctly, is defective or it does not correspond with the programmed type.

The actual-value indication is wrong: The connected sensor does not correspond with the programmed type.

Remedies: Check the sensor. Check the sensor programming. (Sensor level, sensor type, page 15 ff. )

#### 9.2.3. The nominal value cannot be set

Cause: The control range limits have not be been set correctly ( see page 15 )

Or: The unit is programmed for external nominal value ( See page 30 )

### 9.2 .4. The control system is not functioning correctly

If the green LED with the arrow pointing upward is lit and the temperature does not rise, the heating is not connected correctly or it is not powerful enough.

If the green LED with arrow pointing downward is lit and the cooling does not function, check the cooling system for correct functioning.

If the green LED with the arrow pointing upward does not indicate heating although the controller is switched on and the nominal value is above the actual value, the maximum temperature should be checked ( See page 16 ).

The exceeding of the maximum temperature is only indicated when alarm code 1 has been set accordingly ( Level alarm data, alarm code, page 18 ).

If the green LED with the arrow pointing downward does not indicate cooling although the controller is switched on and the nominal value is below the actual value, the set minimum temperature should be checked. ( See page 18 ).

The falling short of the minimum temperature is only indicated when alarm code 2 has been set accordingly ( Alarm level, alarm code, page 19 ).

### 9.2.5. The controller cannot be configured

The code for the entry of the configuring level was wrong. The code can be entered by the user and thus, also has to be managed by him. On a new unit the code is 0. The handling of the code is described under Chapter 6, Adaptation. If the code number has been lost, please contact the manufacturers.

## 9.3. Repairs and guarantee

If the user cannot eliminate a fault the unit has to be sent to the manufacturers for repair. The unit must not be opened by the user nor must it be altered in any way.

The manufacturers guarantee faultless operation of the unit during one year after date of purchase. During this period a defective unit will be repaired at our works in Oberuzwil or it will be replaced, providing the damage is not caused by inappropriate use or by unauthorised manipulation. No other claims are recognised.

## 10. Designation code

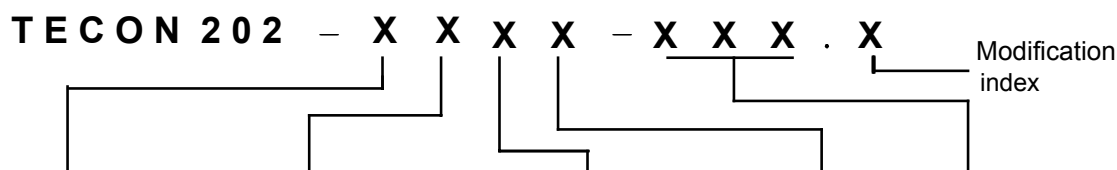

No.	Input	Contr. 1	outputs 2	Analogue 1	outputs 2	Option	Program version
0	NiCr-Ni (K)	relay	relay	voltage	voltage		001: Standard
1	FeCo (J)	signal	relay	current	voltage		
2	PtRh10%(S)	relay	signal	voltage	current		
3	PtRh13%(R)	signal	signal	current	current		
4	Pt100	current	relay				
5	Pt100 + Z-Barr.	relay	current				
6	4-20mA	current	current				
7	0-20mA	signal	current				
8	NiSil (N)	current	signal				
9	PtRh18%(B)						
A	acc. to customer's specific.						

### Ordering specifications

Standard execution:  
Supply voltage 230V, 50Hz/60Hz

Special execution  
please state in the order:

Supply voltage 115V, 50 Hz/60Hz  
or 24V, 50Hz/60Hz

### Controller outputs:

Normally output 1 is used for heating and output 2 for cooling.

The analogue outputs can be programmed for nominal value, actual value, difference nominal - actual, or controller capacity

**Subject to modification without prior notice.**

Art.No. Instruction manual : 096024

**11. List of program data**

Code for program data : \_\_\_\_\_

<b>Program sectors</b>				
Sector	Setpoint	dwell time	Following sector	Remarks
1				
2				
3				
4				
5				
6				
7				
8				
9				
10				
11				
12				
13				
14				
15				
16				

## 12. List of adjustment data

Code for adaptation : \_\_\_\_\_

<b>Alarm data</b>	
Maximum temp. 1	
Minimum temp. 1	
Over temp. 1	
Under temp. 1	
Alarm code 1	
Maximum temp. 2	
Minimum temp. 2	
Over temp. 2	
Under temp. 2	
Alarm code 2	
Alarm code 3	
Threshold sensor	

<b>Serial interface</b>	
Unite Address	
Code serial interface	
Alarm time serial interface	

<b>Sensors</b>	
Sensor 1 : Type	
Current inp. 1, lower limit	
Current inp. 1, upper limit	
Nominal value 1, lower limit	
Nominal value 1, upper limit	
Filter sensor 1	
Sensor 2 : Type	
Current inp.2, lower limit	
Current inp.2, upper limit	
Nominal value 2, lower limit	
Nominal value 2, upper limit	
Filter sensor 2	

<b>Offsets</b>	
Offset 1 (Sensor 1)	
Offset 2 (Sensor 2)	
Offset 3 (nominal value)	

<b>Control parameters</b>	
Proportional band 1	
Integral time 1	
Differential time 1	
Relay interval time 1	
max. capacity 1	
Proportional band 2	
Integral time 2	
Differential time 2	
Relay interval time 2	
max. capacity 2	
Dead band	
Offset nomin. value controller 2	
Adjustment time servo motor	

<b>System data</b>	
Display code	
Code for program run	
digital input	
digital output	
I-Code (current output)	
R-Code (controlling mode)	

<b>Analogue inputs and outputs</b>	
Code analogue input (setpoint)	
Nominal value input lower limit	
Nominal value input upper limit	
Code analogue output 1	
Analogue output 1 range	
Analogue output 1 lower limit	
Analogue output 1 upper limit	
Code analogue output 2	
Analogue output 2 range	
Analogue output 2 lower limit	
Analogue output 2 upper limit	



---

Switzerland:

TECON AG  
Werkstrasse 1

CH 9242 Oberuzwil

Tel. (071) 951 23 33  
Fax (071) 951 15 77

---